

## Switch contacts for pointer instruments

- Model 821, magnetic snap-action contact
- Model 831, inductive contact
- Model 830 E, electronic contact
- Model 851, reed contact

WIKA data sheet IN 00.48

### Applications

- Control and regulation of processes
- Monitoring of plants and switching of circuits
- Indication of limit conditions
- Inductive contact for completely fail-safe switching, even in explosion hazardous areas
- Machine building, general plant construction, chemical industry, petrochemical industry, power plants, mining, on-/offshore and environmental technology

### Special features

- High reliability and long service life
- Can be incorporated within all relevant pressure and temperature measuring instruments
- Up to 3 switch contacts per measuring instrument
- Optionally with liquid-filled case for high dynamic pressure loads and vibrations
- Inductive contact also available in safety version and electronic contact for PLCs

### Description

Switch contacts make or break circuits dependent upon the pointer position of the indicating measuring instrument. The switch contacts are mounted predominantly below the dial, though also partly on top of the dial. DIN 16085 stipulates that the setting range for a contact test is between 10 % and 90 % of the span. The instrument pointer (actual value pointer) moves freely across the entire scale range, independent of the setting. The set pointer for the switch point of circular instruments and square panel-mounted instruments can be adjusted using an adjustment key in the window. Contacts in flush panel-mounted instruments are adjustable using a screwdriver through the window.



Contact pressure gauge with switch contact model 821



Bimetal thermometer with inductive contact model 831

Contact actuation is made when the actual value pointer travels beyond or below the set switch point. Instruments with electrical switch contacts can also be delivered with optional special approvals. Depending on the instrument model, e.g. approvals for hazardous areas are available.

## Model 821, magnetic snap-action contact

### Application

These contacts can be used in almost all operating conditions, and even in liquid-damped instruments.

The set pointer has an adjustable permanent magnet attached, giving a snap-action characteristic to the contacts, which, furthermore, strengthens the contact pressure. This snap action widely protects the contacts against harmful arc influences, but increases the switch hysteresis to 2 % up to 5 % of the measuring span. The hysteresis is the difference of the displayed values, measured by reversing the direction of movement and leaving the switch point unchanged. The signal output is achieved either ahead of or behind the movement of the actual value pointer. The recommended setting range of the contacts is 25 ... 75 % of the scale.

### Specifications and loading tables

If the specified data are observed, the switch contacts ensure perfect operation for many years. Since the switching power of these contact types is limited, for higher loads (max. 2 kVA) and for instruments with liquid filling, a model 905 contact protection relay must be used.

→ See data sheet AC 08.05.

**For low switching voltages, to maintain reliability, the current to be switched should not be less than 20 mA. In order to ensure a high switching reliability of the contacts, even taking ambient influences into account, the switching voltage should not be below 24 V.**

In accordance with DIN 16085, requirements on pressure measuring instruments with contacts for switching currents less than 24 V should be agreed specifically between the user and the manufacturer.

When switching inductive or capacitive loads, the usual contact protection measures against contact erosion should be made.

For programmable logic controllers (PLCs), the model 830 E electronic contact is recommended; → See from page 12.

## Specifications

Limit values for the contact load with resistive load	Model 821, magnetic snap-action contact			
	Unfilled instruments		Filled instruments	
	Switch version "S"	Switch version "L"	Switch version "S"	Switch version "L"
Rated operating voltage $U_{\text{eff}}$	≤ 250 V		≤ 250 V	
Rated operating current <sup>1)</sup>				
Switch-on current	≤ 1.0 A	≤ 0.5 A	≤ 1.0 A	≤ 0.5 A
Switch-off current	≤ 1.0 A	≤ 0.5 A	≤ 1.0 A	≤ 0.5 A
Continuous current	≤ 0.6 A	≤ 0.3 A	≤ 0.6 A	≤ 0.3 A
Switching power	≤ 30 W / 50 VA		≤ 20 W / 20 VA	
Contact material	Silver-nickel (80 % silver / 20 % nickel / gold-plated)			
Ambient temperature	-20 ... +70 °C [-4 ... +158 °F]			
Number of contacts max.	4			

1) Specification of the switch version in the data sheet of the instrument.

## Recommended contact load with resistive and inductive loads

Voltage in V	Model 821, magnetic snap-action contact						Model 811, sliding contact		
(DIN IEC 38) DC / AC	Unfilled instruments			Filled instruments			Unfilled instruments		
	Resistive load		Inductive load	Resistive load		Inductive load	Resistive load		Inductive load
	Direct current	Alternating current	$\cos \phi > 0.7$	Direct current	Alternating current	$\cos \phi > 0.7$	Direct current	Alternating current	$\cos \phi > 0.7$
	mA	mA	mA	mA	mA	mA	mA	mA	mA
220 / 230	100	120	65	65	90	40	40	45	25
110 / 110	200	240	130	130	180	85	80	90	45
48 / 48	300	450	200	190	330	130	120	170	70
24 / 24	400	600	250	250	450	150	200	250	100

## Contact materials

Depending upon the switching conditions, the switch contacts are subjected to greater or lesser erosion due to the effects of the unavoidable arcing and through mechanical stress. As a result, when selecting the contact material, attention should be paid to the predominant operating conditions. The following contact materials are available:

Platinum-iridium is exceptionally chemically resistant, and also hard and very resistant to erosion. It is used for high switching frequencies, high switching powers and in aggressive environments.

### Silver-nickel composite material

(80 % silver / 20 % nickel / gold-plated)

Material properties:

- Higher hardness and rigidity
- Good erosion resistance
- Low inclination to fuse together
- Low contact resistance

Due to its good balance of properties and wide application possibilities, this composite is used as our standard material.

### Platinum-iridium alloy

(75 % platinum, 25 % iridium)

## Other versions

- Contacts with separate circuits
- Change-over contacts (break or make simultaneously at the set point)
- Contacts fixed
- Contacts with parallel resistance 47 kΩ for cable break monitoring
- Contacts self-cleaning (only with NS 160)
- Contact adjustment lock leaded
- Contact adjustment key fixed
- Connector (instead of cable or cable socket)
- Special contact material platinum-iridium alloy

## Switching functions

The following applies, as a general rule, to the switching functions of the model 821 magnetic snap-action contacts with our standard settings:

- Index 1** behind the contact model no. means: **Contact makes** the circuit when the set point is exceeded.
- Index 2** behind the contact model no. means: **Contact breaks** the circuit when the set point is exceeded.
- Index 3** behind the contact model no. means: When the set value is exceeded, one circuit breaks and one circuit makes **simultaneously** (change-over contact).

For switch contacts with multiple contacts, the 1st contact is the one closest to the left start of scale value.

**The switching function**, described in the following table, follows the **clockwise rotary motion** of the instrument pointer (actual value pointer).

If the actual value pointer moves **anticlockwise**, the **reverse switching function** occurs!

**Note:** If the switch contacts are to be set (adjusted) anticlockwise, the index figures in brackets must be used in accordance with DIN 16085. Combinations are possible.

Circuit diagram	Switching function on pointer movement in a clockwise direction	Contact model with index of the switching function
<b>Single contact <sup>1)</sup></b>		
	Contact makes when the set point is exceeded	821.1 (.5)
	Contact breaks when the set point is exceeded	821.2 (.4)
	Contact changes over (change-over contact), i.e. 1 contact breaks and 1 contact makes when the set point is exceeded	821.3 (.6)
<b>Double contact <sup>1)</sup></b>		
	1st and 2nd contact makes when the set points are exceeded	821.11 (.55)
	1st contact makes, 2nd contact breaks when the set points are exceeded	821.12 (.54)
	1st contact breaks, 2nd contact makes when the set points are exceeded	821.21 (.45)
	1st and 2nd contact breaks when the set points are exceeded	821.22 (.44)
<b>Triple contact <sup>1)</sup></b>		
	1st contact breaks, 2nd contact makes, 3rd contact breaks when the set points are exceeded	821.212 (.454)

1) When ordering, attach the corresponding index of the required switching functions (note order 1st, 2nd, 3rd contact) to the contact model no., see example 821.212.

The **connection terminals** and **connection wires** are marked in accordance with the table above. Protective conductors are always yellow-green.

## Model 851, reed contact

### Application

Reed contacts are often used for switching small voltages and currents, since their hermetically sealed design, in combination with contacts in inert gas, cannot become corroded on the contact surfaces. Their high reliability and low contact resistance make them suitable for a large number of applications. They include, for example, PLC applications, signal conversion in measuring instruments, signal lights, acoustic signal transmitters and many more. Their hermetically sealed design makes these contacts ideally suited for use at high altitudes. Reed contacts need no auxiliary supply voltage and are very insensitive to vibrations, due to their low weight. For 2 contacts, the individual switches are galvanically separated from each other.

### Note

Due to its ability to simultaneously switch both the smallest currents and voltages as well as powers of up to 60 watts, this contact form is ideal for applications in which the signal has not yet been exactly defined in the planning phase.

### Design and function

A reed contact consists of three contact tongues (change-over contact, SPDT), made of a ferromagnetic material, which are fused in a glass body under an inert gas atmosphere.

To minimise wear and guarantee a low contact resistance, the contact tongues are provided with a metal coating in the area of the contact surfaces. The reed contact is actuated by an external magnetic field, e.g. permanent magnet.

The switching status is maintained until the magnetic field strength has fallen below a certain value.

Predominantly, WIKA uses mainly bistable and magnetically-biased reed contacts. The bias maintains the signal status until a magnetic field having the opposite magnetic polarity resets the contact.

Due to the hard coating of the contact surface with, for example, ferromagnetic rhodium, the reed contact achieves a very long service life. The number of possible switching cycles of a reed contact depends largely on the level of the electrical load, but, based on experience, is in the range of 10<sup>6</sup> to 10<sup>7</sup>.

### Functionality

Reed contact SPDT (change-over contact) not activated

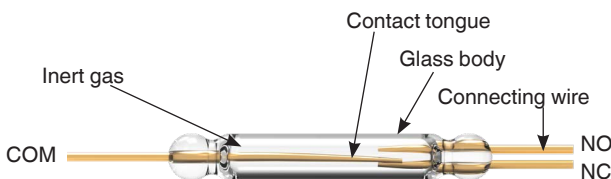

COM = Common contact  
NC = Normally closed  
NO = Normally open

If only signal loads or small loads are switched, then switching operations in excess of 10<sup>8</sup> are easily achievable. With switching voltages below 5 V (arcing limit), switching operations beyond 10<sup>9</sup> can be achieved. For capacitive or inductive loads, the use of a protective circuit is required since the resulting current, or voltage spikes would destroy the reed contact or at least significantly reduce its service life. For this, see the chapter on contact protection measures on page 8.

If a magnetic field passes the reed contact, both contact tongues attract each other and close the contact. The electrical current can flow.

If the magnetic field moves away, the field strength drops with increasing distance. The contact remains closed through the bistability. Only a new traverse of the reed contact with a magnetic field in the opposite direction opens the two contact tongues again. The electrical current is interrupted.

As with other mechanical switches, the reed contact is also not bounce-free. However, the bounce times are shorter than most other mechanical contacts. Nevertheless, this physical property should be considered, especially in PLC applications (keyword: software debounce / button debounce).

### Example:

If the switch point for a 10 bar switchGAUGE is set, for example, to 1 bar and the instrument pointer sweeps this value with the magnet in the positive direction, the reed contact will change state and maintain it, even if the pointer continues to 10 bar.

The reed contact will only further change its state if the pointer passes 1 bar in the direction of 0.

Reed contact SPDT (change-over contact) activated

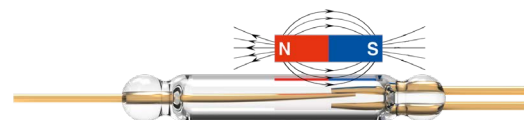

## Specifications for model 851, reed contact

Limit values for the contact load with resistive load	
Contact version	Change-over contact
Type of contact	Bistable
Max. switching voltage	AC 250 V / DC 250 V
Min. switching voltage	Not required
Switching current	≤ 1 A
Min. switching current	Not required
Transport current	≤ 2A
cos φ	1
Switching power	60 VA/W
Contact resistance (static)	100 mΩ
Insulation resistance	10 <sup>9</sup> Ω
Breakdown voltage	DC 1,000 V
Switching time incl. contact chatter	4.5 ms
Contact material	Rhodium
Switch hysteresis	3 ... 5 %

- The limit values presented here must not be exceeded independently of each other.
- When using two contacts, these cannot be set to the same point. In this case, a minimum clearance of approx. 30° is required.
- The adjustment range of the contacts is 10 ... 90 % of the scale.
- The switch hysteresis can be set in manufacturing such that the reed contact will actuate exactly at the required switch point. For this, the switching direction is required on order.
- In other pressure gauges, e.g. model 700.0x and 230.15 2", further reed contacts are used. For the specifications, please refer to the respective data sheet.

# Operating limits for magnetic snap-action or reed contacts

## General information

Each mechanical switch has 4 physical limits.

- Maximum electrical switching voltage
- Maximum electrical switching current
- Maximum electrical load to be switched
- Maximum mechanical switching frequency

Outside these specified physical limits, the switch should not be operated. Should even only one of these limits be exceeded during operation, the service life of the switch will be shortened. The further that one or more limits are exceeded, the greater the shortening of the service life of the switch, even as far as immediate failure.

### Maximum electrical switching voltage

When switching an electrical load, an arc may arise, more or less visible, between the contact surfaces. Due to the resulting, locally limited, high heat, the contact material gradually evaporates during each switching process (material loss, erosion). The higher the voltage to be switched, the larger are the arcs and thus the contact material evaporates more and faster.

The contact will be permanently damaged.

### Maximum electrical switching current

When switching an electrical current, the contact surface will be heated through the charge carrier flow (contact resistance). If the maximum permissible switching current is exceeded, the contacts begin to fuse together. This can lead to the welding or sticking of the two contact surfaces. The contact will be permanently damaged.

### Maximum electrical power

The maximum electrical power which a contact can switch is defined as the switching voltage multiplied by the switching current. This electrical power heats the contact and should not be exceeded (welding, sticking).

The contact will be permanently damaged.

### Maximum mechanical switching frequency

The maximum possible switching frequency is dependent upon the wear of the bearing points and also the material fatigue.

### Minimum electrical values

Each mechanical contact has a contact resistance due to impurity layers (impurity-film resistance  $R_F$ ). This impurity-film resistance exists through oxidation or corrosion on the contact surfaces and increases the electrical resistance of the switch. With switching of small loads, this layer is not penetrated. Only by switching higher voltages and currents is this destroyed. This effect is known as fritting, and the required minimum voltage is the fritting voltage. If this voltage is not reached when switching, the impurity-film resistance will continue to increase and the switch will cease to work. This effect is reversible.

### Further notes

Such electrical overloads can be based, for example, on the following:

- Filament lamps absorb up to 15 times more current at the moment of switching-on than during operation (nominal value).
- Capacitive loads, at the moment of switching on, create a short-circuit (long control lines, lines running parallel to each other).
- Inductive loads (relay, fuse, solenoid valve, rolled cable drum, electric motors) generate, on switching, very high voltages (up to 10 times the rated voltage).

## Contact protection measures

Mechanical contacts must not exceed the specified electrical values for switching current and switching voltage, not even for a short time only.

For capacitive or inductive loads we recommend one of the following protective circuits.

### 1. Inductive load with DC voltage

With DC voltage the contact protection can be achieved via a free-wheeling diode, connected in parallel to the load. The polarity of the diode must be arranged so that it closes when the operating voltage is on.

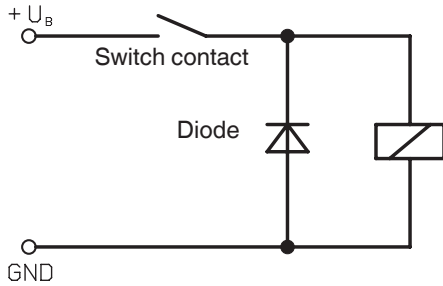

**Example: Contact protection measure with free-wheeling diode**

### 2. Inductive load with AC voltage

With AC voltage, two protection measures are possible.

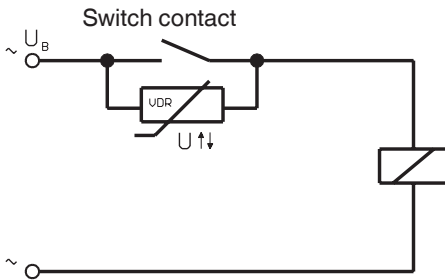

**Example: Contact protection measure with voltage-dependent resistor VDR**

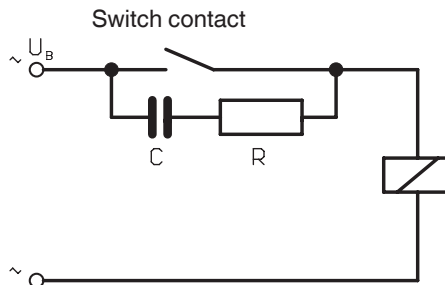

**Example: Contact protection measure with RC element**

### 3. Capacitive load

With capacitive loads elevated switch-on currents arise. These can be reduced by series-connecting resistors in the supply line.

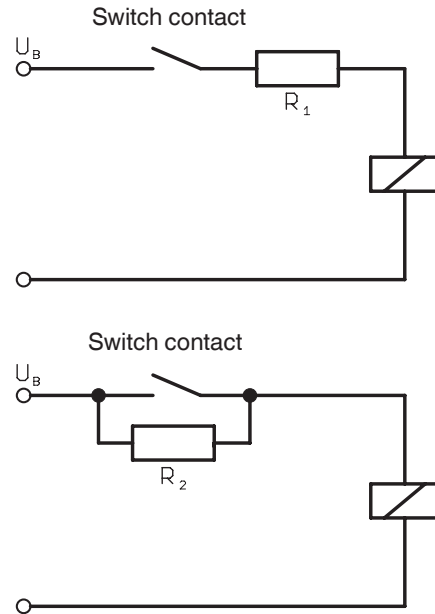

**Example: Contact protection measure with current-limiting resistor**

### Contact curve

The hatched area of the contact curve shows the permissible electrical values for the respective contact.

The voltage to be switched must neither be above the maximum nor below the minimum switching voltage ( $V_{\max} \leq U_s \leq V_{\min}$ ).

The current to be switched must neither be above the maximum nor below the minimum switching current ( $A_{\max} \leq I_s \leq A_{\min}$ ).

The power to be switched may only lie below the limit curve.

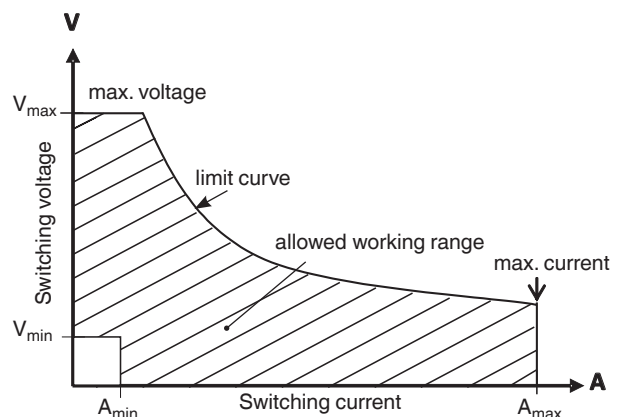



## Model 831, inductive contact

### Application

Measuring instruments with WIKA inductive contacts may be used in zone 1 and 2 hazardous areas. Provided that they are supplied from a suitable and certified control circuit (e.g. WIKA model 904.28 control unit).

Outside of hazardous areas, these WIKA inductive contacts are primarily used where particularly safe switching at higher switching rates is important. Since the contacts also work in liquid filling, such instruments can even be used in very specific operating conditions. Some typical application areas are in chemical, petrochemical and nuclear plants.

### Functional principle

The WIKA inductive contact works in a non-contact way. Essentially, it consists of the control head (initiator), attached to the set pointer, with its fully potted electronics and the mechanical assembly with the moving flag. The flag is moved by the instrument pointer (actual value pointer). The control head is supplied with a DC voltage. When the flag enters the slot in the control head, this then increases its internal resistance (= damped condition / the initiator has high impedance). The subsequent change in the current acts as the input signal for switching amplifiers of the control unit.

### Advantages of the WIKA inductive contact

- Long service life due to non-contact switching
- Low influence on the display
- Universal application, even with filled instruments
- Insensitive to aggressive environments (potted electronics, non-contact switching)
- Explosion-protected, can be used in zone 1 and 2

### Design concept of the WIKA inductive system

The WIKA inductive system consists of the WIKA inductive contact built into the measuring instrument (as already described) and a model 904 control unit; → See data sheet AC 08.04.

The **control unit** consists of

- Power supply unit
- Switching amplifier
- Output relay

The power supply unit converts the mains voltage for the control unit. The switching amplifier supplies the control head and switches the output relay. Via the output relay, high electrical powers can be switched.

There are two **versions of control unit:**

- **Non-intrinsically safe version** (non-Ex version)
- **Intrinsically safe version** (Ex version)

### Functional diagram

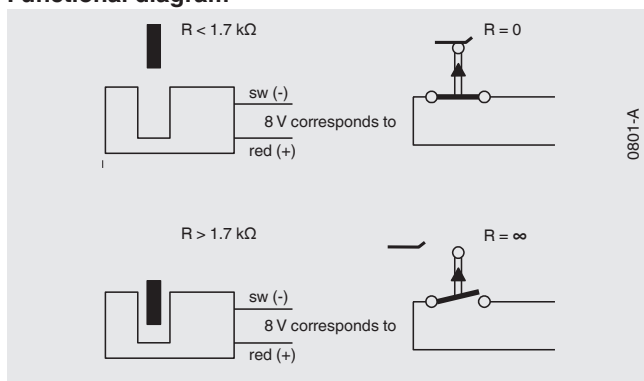

The control unit effectively works without influence on the measuring system. The non-contact switching produces no wear within the electrical system. The assembly dimensions correspond to the model 821 contacts. Setting of the set points is carried out as for these contacts.

Ambient temperature: -25 ... +70 °C [-13 ... +158 °F] <sup>1)</sup>

Control head used (slot sensor): Model 831

<sup>1)</sup> With use in hazardous areas, the prescribed upper limit values for the ambient temperature must be observed! These are dependent upon the voltage, current, power and temperature class.

## Switching functions

The following applies, as a general rule, to the switching functions of the model 831 inductive contacts in connection with our standard settings:

**Index 1** behind the inductive contact model no. means: **Contact makes** the control circuit when the set point is exceeded (flag moves **out of the control head**).

**Index 2** behind the inductive contact model no. means: **Contact breaks** the control circuit when the set point is exceeded (flag moves **into the control head**).

For inductive contacts with multiple contacts, the 1st contact is the one closest to the left start of scale value or end value (be careful with vacuum gauges).

**The switching function**, described in the following table, follows the **clockwise rotary motion** of the instrument pointer (actual value pointer). If the actual value pointer moves **anticlockwise**, the **reverse switching function** occurs!

**Note:** If the inductive contacts are to be set (adjusted) anticlockwise, the index figures in brackets must be used in accordance with DIN 16085. Combinations are possible.

Circuit diagram <sup>2)</sup>	If the pointer of the measuring instrument moves clockwise, on exceeding the defined set point, the flag is driven:	Switching function (illustration of the principle)	Inductive contact model with index of the switching function
<b>Single contact <sup>1)</sup></b>			
	out of the control head	Contact makes	 831.1 (.5)
	into the control head	Contact breaks	 831.2 (.4)
<b>Double contact <sup>1)</sup></b>			
	of the 1st and 2nd contact out of the control head	1st and 2nd contact makes	 831.11 (.55)
	of the 1st contact out of the control head, the 2nd contact into the control head	1st contact makes, 2nd contact breaks	 831.12 (.54)
	of the 1st contact into the control head, the 2nd contact out of the control head	1st contact breaks, 2nd contact makes	 831.21 (.45)
	of the 1st and 2nd contact into the control head	1st and 2nd contact breaks	 831.22 (.44)

### Triple contact <sup>1)</sup>

A number of instruments can be fitted with up to 3 inductive contacts.

→ For technical notes, see page 11.

Switching and switch behaviour in principle as in the previous table.

1) When ordering, attach the corresponding index of the required switching functions (note order 1st, 2nd, 3rd contact) to the inductive contact model no.

2) Thin line means: Flag in control head, control circuit open. Thick line means: flag out of the control head, control circuit closed

The **connection terminals** and **connection wires** are marked in accordance with the table above.

## Triple contact

With standard inductive contacts in the triple design, the setting of all three contacts to the same set point is not physically possible. Either the left (= 1st contact) or the right contact (= 3rd contact) must be separated by  $\geq 30^\circ$  to the left or the right of the two set pointers, which may be set to the same value:

### Examples

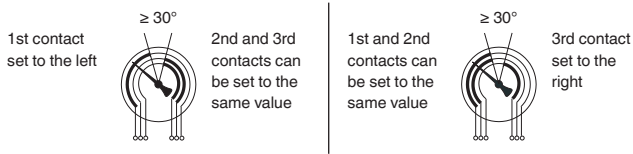

## Combination of all triple contacts

The 1st set pointer is set approx.  $30^\circ$  to the left

The 3rd set pointer is set approx.  $30^\circ$  to the right

Model	Model
831.1.11	831.11.1
831.1.12	831.11.2
831.1.21	831.12.1
831.1.22	831.12.2
831.2.11	831.21.1
831.2.12	831.21.2
831.2.21	831.22.1
831.2.22	831.22.2

## Safety inductive contacts

### Safety inductive contact, model 831 SN and 831 S1N

For safety-critical applications, such as for the construction of self-monitoring controls, type-tested components must be used. Corresponding certifications are available for the model 831 SN and model 831 S1N safety inductive contacts. The precondition is operation with a similarly certified fail-safe control unit (isolating amplifier), e.g. model 904.30 KHA6-SH-Ex1; → See data sheet AC 08.04.

Measuring instruments with safety inductive contacts may be used in zone 1 hazardous areas. Control head used (SN/S1N slot sensor): Model 831 from Pepperl+Fuchs.

### Switch behaviour, model 831 SN

If the flag is in the slot sensor, then the output of the downstream control unit (0 signal) is **inhibited**, i.e. the output relay is **de-energised** (= safe state).

For the index of the switching functions, the emergence of the flag out of or insertion into the control head and also the installation options, the same information applies as for model 831 inductive contacts.

### Switch behaviour, model 831 S1N

If the flag is not in, but rather **outside** the slot sensor, then the output of the downstream control unit (0 signal) is inhibited, i.e. the output relay is **de-energised** (= safe state).

For the index of the switching functions, the same information applies as for model 831 inductive contacts with the following difference:

**Index 1** behind the inductive contact model no. means: **Contact makes** the control circuit when the set point is exceeded in the clockwise direction (flag moves **into the control head**).

**Index 2** after the inductive contact model no. means: **Contact breaks** the control circuit when the set point is exceeded in the clockwise direction (flag moves **out of the control head**).

## Special version

### Triple contact NS 160, settable to one set point

If the setting of 3 contacts to a single set point is absolutely needed, then this can be achieved with NS 160 through the use of a smaller control head. This must be defined on ordering.

## Model 830 E, electronic contact

### Description, application

Direct switching of small capacities which are usually required in connection with a programmable logic controller (PLC) can be realised by this inductive contact with integrated switching amplifier model 830 E which is factory-installed directly into the measuring instrument.

The usual advantages of inductive contacts, such as fail-safe switching, no wear due to non-contact switching as well as practically no effect on the measuring system, also apply here.

### No additional control unit is required.

The electronic contact can be selected with 2- or 3-wire design and is implemented with PNP output. The operating voltage is DC 10 ... 30 V. The maximum switching current is 100 mA.

The model 830 E electronic contact is **not intrinsically safe** and therefore not suitable for applications in hazardous areas!

For the index of the switching functions, the same information applies as for model 831 inductive contacts with the following difference:

**Index 1** behind the inductive contact model no. means: **Contact makes** the control circuit when the set point is exceeded in the clockwise direction (flag moves **into the control head**).

**Index 2** after the inductive contact model no. means: **Contact breaks** the control circuit when the set point is exceeded in the clockwise direction (flag moves **out of the control head**).

**Note:** The direction of the action of the flag is also reversible, as with model 831!

### Electrical connection

Control and switching electronics in the sensor, electrical connection via cable socket

- To connect a PLC control unit or for direct switching of small capacities
- PNP transistor  
With PNP switching apparatus, the switched output is a connection towards PLUS. The load  $R_L$  between the switched output and the MINUS should be selected in a way not to exceed the maximum switching current of 100 mA.
- Flag emerges from slot sensor: Contact open (output not active)
- Flag retreats into slot sensor: Contact closed (output active)

### 2-wire system (standard)

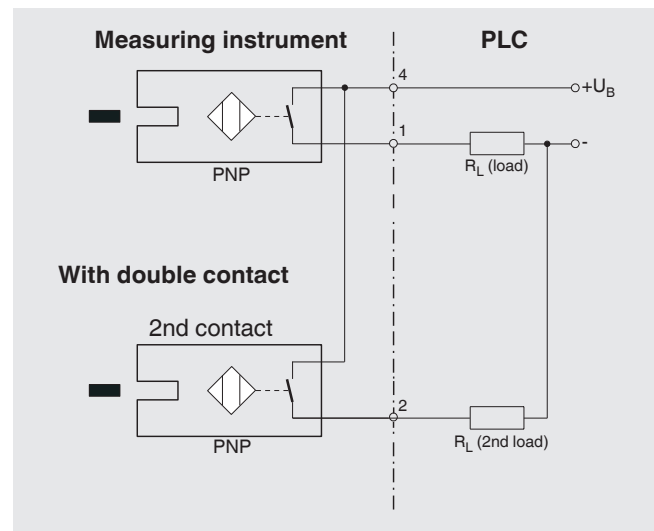

### 3-wire system

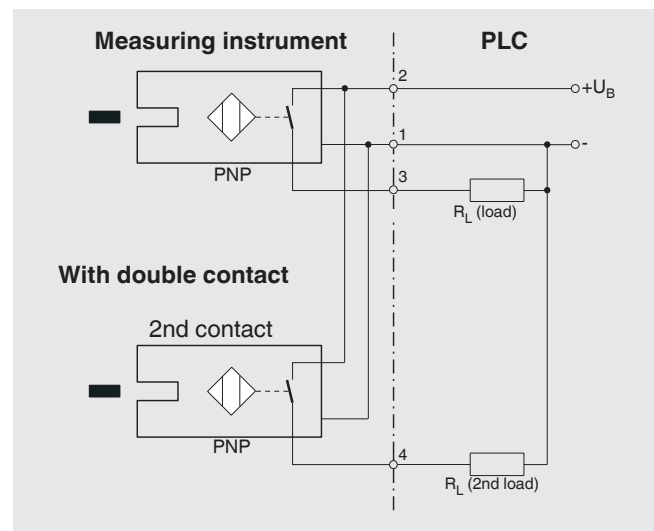

## Specifications for model 830 E, electronic contact

Specifications	
Supply voltage	DC 10 ... 30 V
Residual ripple	max. 10 %
No-load current	≤ 10 mA
Switching current	≤ 100 mA
Residual current	≤ 100 μA
Function of switching element	Normally open
Type of output	PNP transistor
Voltage drop (with I <sub>max.</sub> )	≤ 0.7 V
Reverse polarity protection	conditional UB (the output 3 or 4 switch must never be set directly to minus)
Anti-inductive protection	1 kV, 0.1 ms, 1 kΩ
Oscillator frequency	Approx. 1,000 kHz
EMC	Per EN 60947-5-2
Installation	Direct in measuring instrument, maximum 2 inductive contacts possible

© 07/2022 WIKA Alexander Wiegand SE & Co. KG, all rights reserved.  
The specifications given in this document represent the state of engineering at the time of publishing.  
We reserve the right to make modifications to the specifications and materials.

