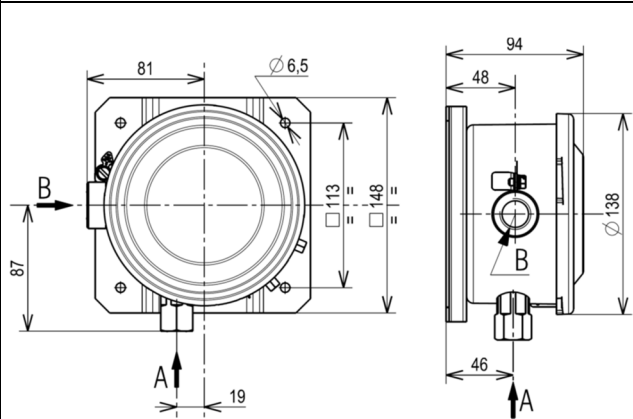
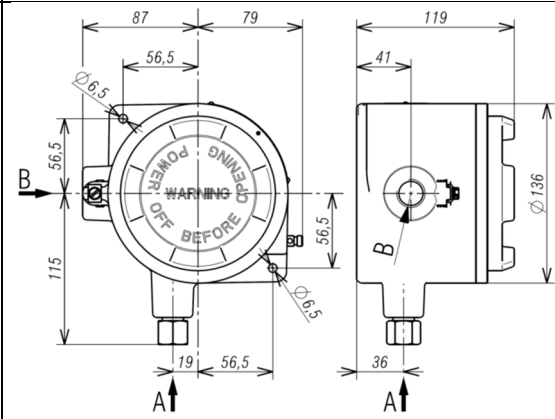

## BOURDON PRESSURE SWITCHES SERIE BW, BAX AND BA

### WEATHERPROOF AND INTRINSICALLY SAFE: SERIE BWX

**WEIGHT 2,0 kg**

### FLAMEPROOF: SERIE BA

**WEIGHT 2,4 kg**

### FLAMEPROOF: SERIE BAX

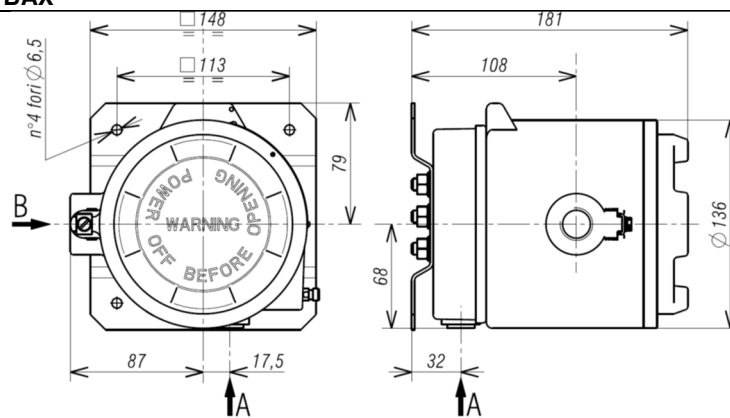
**WEIGHT 3,7 kg**

For surface mounting use screws M6 dimensions in mm

**A= pressure connection B= cable entry**
**NOTE:** dimensions and weights are not binding unless released on certified drawings.

**CAUTION**

- Before installing, using or carrying out maintenance on the instrument it is necessary to **read** and **understand** the indications given in the attached Instruction Manual.
- The instrument must only be installed and maintained by **qualified personnel**.
- **INSTALLATION IS TO BE CARRIED OUT ONLY AFTER CHECKING THAT INSTRUMENT CHARACTERISTICS ARE CONSISTENT WITH PROCESS AND PLANT REQUIREMENTS.**
- The functional **features** of the instrument and its degree of protection are shown on the identification plate fixed to the case.

**CONTENTS:**

- 1 GENERAL NOTES
- 2 OPERATING PRINCIPLE
- 3 MODEL CODE
- 4 IDENTIFICATION PLATE AND MARKINGS
- 5 SET POINT REGULATION
- 6 SET POINT CALIBRATION
- 7 MOUNTING AND CONNECTIONS
- 8 INSTRUMENT PLUMBING
- 9 SAFETY INTEGRITY LEVEL (SIL) INSTALLATION REQUIREMENTS
- 10 PUTTING INTO OPERATION
- 11 VISUAL INSPECTION
- 12 FUNCTIONAL VERIFICATION
- 13 STOPPING AND DISMOUNTING
- 14 DISPOSAL
- 15 TROUBLESHOOTING

### RELATED DOCUMENT

To authenticated document with certificate

N° IECEx PRE 16.0069X

N° IECEx PRE 16.0070X

N° IECEx PRE 16.0074X

SAFETY INSTRUCTIONS FOR USE IN HAZARDOUS ATMOSPHERES.

RECOMMENDATIONS FOR PRESSURE SWITCH SAFE USE.

All data, statements and recommendations supplied with this manual are based on information believed by us to be reliable. As the conditions of effective use are beyond our control, our products are sold under the condition that the user himself evaluates such conditions before following our recommendations for the purpose or use foreseen by him.

This document is the property of ALEXANDER WIEGAND SE & Co and may not be reproduced in any form, nor used for any purpose other than that for which it is supplied

### 1 GENERAL NOTES

#### 1.1 FOREWORD

The wrong choice of a series or a model, as well as the incorrect installation, lead to malfunction and reduce instrument life. Failure to abide by the indications given in this manual can cause damage to the instrument, the environment and persons.

#### 1.2 ALLOWED OVERRANGE

Pressure exceeding the working range can be **occasionally** tolerated provided they remain within the limits stated in the instrument features (vacuum or proof pressure). **Continuous** pressures exceeding the working range can be applied to the instrument provided they are clearly stated in the instrument features. The current and voltage values stated in the technical specifications and ratings must **not** be exceeded. Transitory overages can have a destructive effect on the switch.

#### 1.3 MECHANICAL VIBRATION

Can generally lead to the wearing of some parts of the instrument or cause spurious action. It is therefore recommended that the instrument be installed in a place where there are no vibrations. In cases where this is impossible it is a good idea to take measures to lessen the effects (elastic supports, installation with the switch plunger of the microswitch positioned at right angles to the vibration plane).

#### 1.4 TEMPERATURE

Due to the temperature of both the environment and the process fluid, the temperature of the instrument could exceed the allowed limits (normally from -40° to +60°C). Therefore, in case it does, suitable measures (protection against heat radiation, fluid separators, cooling coils, heated lockers) must be taken. The process fluid or its impurities must not however solidify in the instrument.

### 2 OPERATING PRINCIPLE

The pressure, acting on the sensitive element (bourdon tube), determines its elastic deformation which is used to activate one or two electric microswitches regulated at set point values. The microswitches are of the rapid release type with automatic rearm. When the pressure moves away from the set values, returning towards the normal values, the switch is rearmed. The dead band (gap between the set point value and the reset value) can be fixed or adjustable (letter R in the contact codes).

### 3 MODEL CODE

See Annex 1

### 4 IDENTIFICATION PLATE AND MARKINGS

The instrument is fitted with a metal plate bearing all its functional characteristics and in case of flameproof or intrinsic safety execution also the markings prescribed by standard IEC/EN 60079-0. Fig.1 shows the plate mounted on flameproof instruments.

Fig. 1 - Flameproof instruments plate

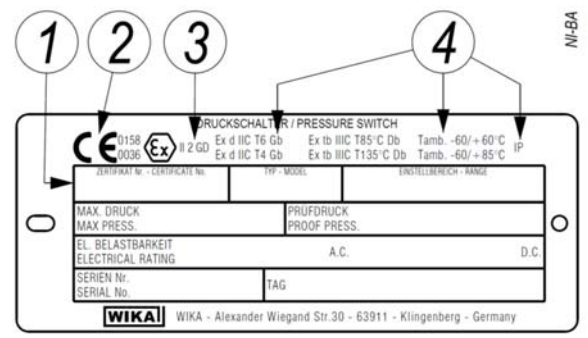

- 1 Notified body that issued the type certificate and number of said certificate.
- 2 CE marking and identification number of the notified body responsible for production surveillance.
- 3 Apparatus classification according to ATEX 2014/34/EU directive.
- 4 Type of protection and ambient temperature limits of operation.

The following table gives the relationship between hazardous areas, Atex Categories and Equipment Protection Level (EPL) listed on the flameproof instrument nameplate.

Hazardous area		Categories according to 2014/34/EU Directive (ATEX)	EPL
Gas, vapours, fog	Zone 0	1G	Ga
Gas, vapours, fog	Zone 1	2G or 1G	Gb or Ga
Gas, vapours, fog	Zone 2	3G, 2G or 1G	Gc, Gb or Ga
Dust	Zone 20	1D	Da
Dust	Zone 21	2D or 1D	Db or Da
Dust	Zone 22	3D, 2D or 1D	Dc, Db or Da

### 5 SET POINT REGULATION

Each microswitch is independent and can be adjusted by means of a screw (for adjustment) to snap when the pressure reaches (increasing or decreasing) the desired value (set point). The instrument is usually supplied with the switches adjusted at the setting range value nearest to zero (**factory calibration**). The instrument is supplied with a label showing the set point calibration value. With **factory calibration** the values are not indicated, as these are temporary and will be modified with the definitive values. Prior to installation the instrument must **be calibrated** and the definitive calibration values written on the label.

If the instrument has been ordered with a **specific calibration**, check the calibration values marked on the relevant label, prior to installation.



The position of the adjustment screw is given in figure 2.

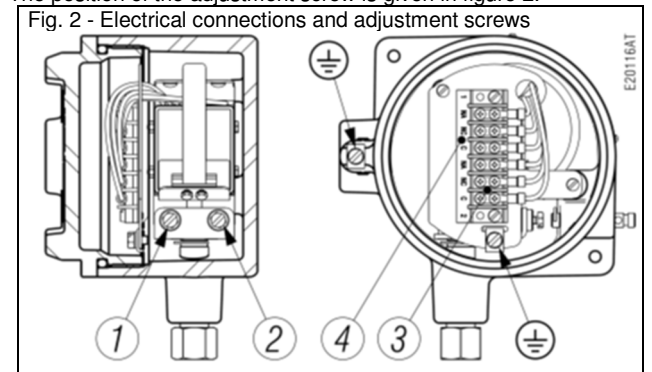

- 1- Microswitch 2 set point calibration screw
- 2- Microswitch 1 set point calibration screw
- 3- Electrical connection identification plate
- 4- Terminal block

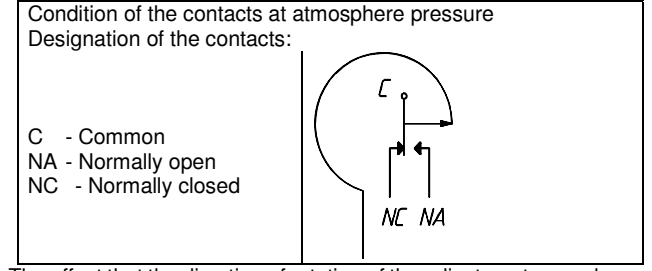

The effect that the direction of rotation of the adjustment screw has is described on the label.

### 6 SET POINT CALIBRATION

In order to proceed with the calibration and the periodical functional verification of the instrument a suitable **calibration circuit** (Fig. 3) and an adequate pressure source is required. The test instrument should have a measurement range approximately equal to or slightly wider than the pressure switch range and should have an accuracy consistent with the accuracy required to calibrate the set point.



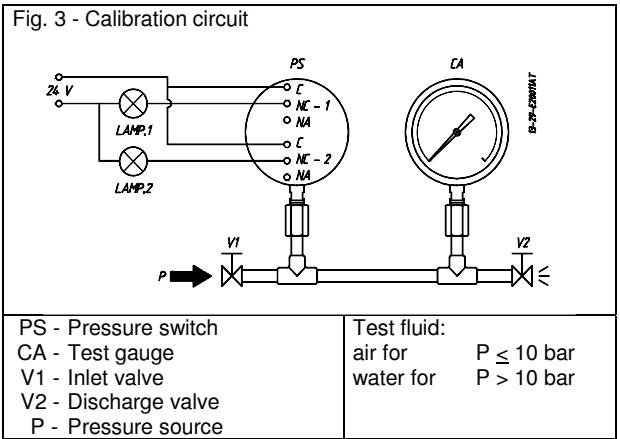

- If the circuit is closed at the working pressure, the switch **opens** the circuit as the pressure **increases** when the desired value is reached.
- If the circuit is open at the working pressure, the switch **closes** the circuit as the pressure **decreases** when the desired value is reached.

The pressure switch must be mounted in the normal installation position, i.e. with the pressure connection pointing downwards. Avoid forcing the elastic support of the microswitch by hand or with tools. This could affect the instrument functioning.

**CAUTION:** if the switch is of the kind with adjustable dead band (letter R in the contact codes) before proceeding with the following operations it is necessary to proceed with the adjustment of the dead band.



Increase the pressure in the circuit up to the desired set point value for the first microswitch. Use a wide bladed screwdriver, as indicated on the label, turn the screw until the relative lamp turns on (or turns off).

- If the instrument is equipped with only **one contact** the calibration is complete.
- If it is equipped with **two contacts** continue in the following manner. Vary the pressure until the desired set point value for the second microswitch is reached. Act on the adjustment screw of the second contact.

Repeat calibrating operations on the first contact, then on the second contact, until the required set point accuracy is obtained. This is necessary due to the reciprocal influence which the microswitches have on the sensitive element of the instrument.

**CAUTION:** if the two set point are different they must be different for much of 5% of the adjustable span.



## 6.1 PRELIMINARY OPERATIONS

### 6.1.1 Weatherproof pressure switches (Series BWX)

Remove the blocking device fixed to the side of the instrument case and the adjustment screw access plate (Fig. 4). Remove the cover by rotating it in an anticlockwise direction.

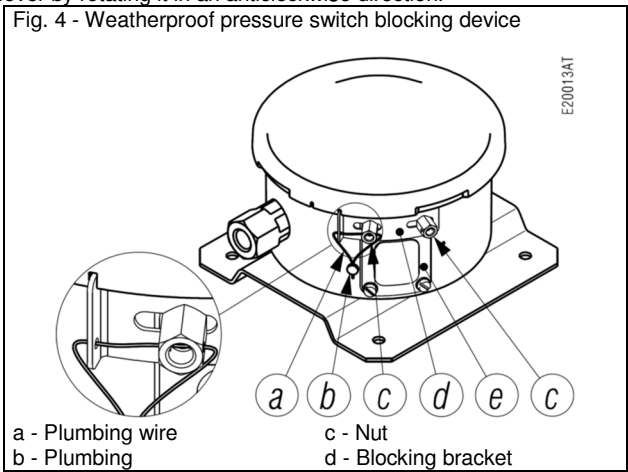

### 6.1.2 Flameproof pressure switches (Series BA and BAX)

**CAUTION:** do not open the cover of pressure switches when energized, in explosive atmospheres.



Loosen the locking headless screw situated on the cover using a 1,5 hexagonal key then unscrew the cover (fig.5). Remove the internal blocking device inserted on the closure plugs and slide out the plugs.

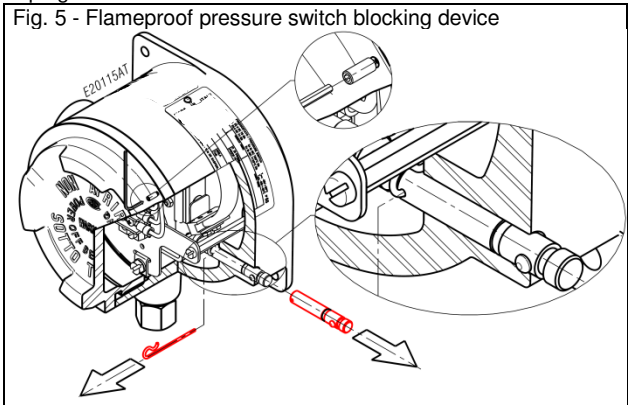

## 6.2 CALIBRATION CIRCUIT AND OPERATIONS

Prepare the calibration circuit as indicated in Fig.3. The warning lamps should be connected to contact 1 or 2 in the NO or NC position according to the required contact action.

### Connection of C and NO terminals

- If the circuit is open at the working pressure, the switch **closes** the circuit as the pressure **increases** when the desired value is reached.
- If the circuit is closed at the working pressure, the switch **opens** the circuit as the pressure **decreases** when the desired value is reached.

### Connection of C and NC terminals

## 6.3 CHECK OF SET POINT

Generate the normal working pressure and wait the pressure stabilisation. Vary the pressure into the circuit and record the set point value. Write the set point values on the adhesive label.

**Note:** the repeatability should be checked verifying for three times the set point (Pi) starting always from the same pressure value (Pw). The pressure cycle should be slowly to give the possibility to record the set point with accuracy.

## 6.4 ADJUSTMENT OF DEAD BAND (LETTER R ON THE MODEL CODE)

The dead band can be adjusted only on the instrument is equipped with a microswitch, which allows adjusting (Letter R on the model code). Adjustment may be obtained by rotating the wheel placed on the microswitch (Fig. 6).

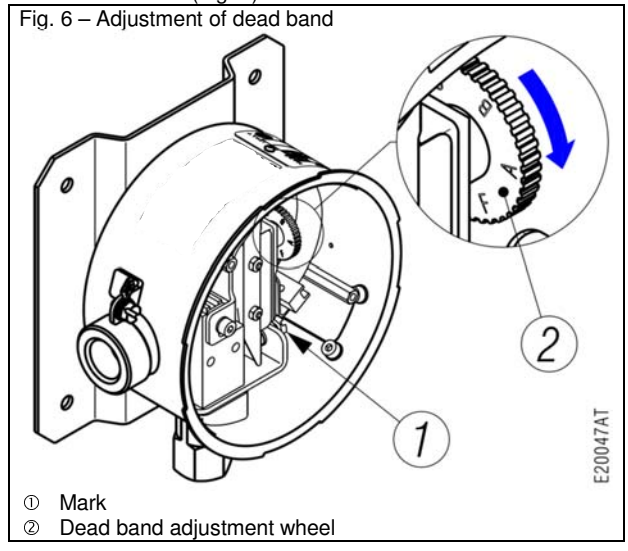





In order to carry out this operation it is advisable to use a blade screwdriver.

**WARNING:** rotate the wheel without pushing too much the blade against it.

The instrument is normally delivered adjusted on the **minimum value** of its range (factory calibration).

### 6.4.1 Calibration of dead band

The calibration of the dead band is obtained using the following procedure:

- 1 - Raise pressure in the circuit until reaching the set point and record its value (Pi).
- 2 - Reduce pressure in the circuit until reaching the reset point and record its value (Pr).
- 3 - The difference  $P_i - P_r = V_a$  represents the dead band factory adjusted value.
- 4 - Rotate the adjustment wheel in the sense shown in Fig. 6 placing the red notch in horizontal position
- 5 - Repeat operations 1 and 2 and measure the new dead band Vb.
- 6 - By comparing the values  $V_a$  and  $V_b$  approximately determine the color of the wheel notch to be placed on the mark.
- 7 - Place the notch and measure the obtained dead band.
- 8 - Proceed by successive approximations until reaching the desired dead band value with enough accuracy.
- 9 - Then proceed with the set point calibration

**Example:** The dead band increase corresponding to the rotation from A to B is given by:  $V_b - V_a = I$

The desired dead band V will be approximately in the position indicated by the value  $K = V/I$  which expresses:

- By units, the wheel notches (1=one black notch, 2=one red notch, 3=one yellow notch, 4=one blue notch, 5=one green notch, 6=two black notches).
- By decimal digits, the percentage middle position between the located notch (of units) and the following one.

### 6.5 FINAL OPERATIONS

Disconnect the instrument from the calibration circuit.

#### 6.5.1 Weatherproof pressure switches (Series BWX)

Take the cover, ensure that the sealing gasket is correctly fitted into its seat, and insert the cover onto the case, with the blocking gap positioned in correspondence to the blocking bracket.

Turn the cover clockwise closing it tightly. Mount the blocking device as in Fig. 4. Mount on pressure connection and cable entry the protection caps supplied with the instrument.

#### 6.5.2 Flameproof pressure switches (Series BA and BAX).

Insert the closure plugs of the adjustment screw access holes, **block** them using the internal device and if necessary seal them with plumbing. Screw on the cover and **block** it using the headless screw with which it is equipped (Fig. 5)

#### 6.5.3 Final operations

Mount on pressure connection and cable entry the protection caps supplied with the instrument.

**Caution:** The protection caps should only be definitively removed **during** the connection steps (see § 7).



## 7 MOUNTING AND CONNECTIONS

### 7.1 MOUNTING

**Surface** mount the instrument by means of the holes provided, or **pipe** mount using the appropriate bracket or mount directly on process **in a vertical position** (with the pressure connection downwards) (See fig. 16,17,18).

In case of surface or panel or rack mounting the instruments can be mounted side by side (see Fig.21). The chosen position must be such that vibrations, the possibility of shocks or temperature changes are within tolerable limits.

With gas or vapour process fluid, the instrument **must** be positioned higher than the pipe inlet (see Fig. 20). With a liquid process fluid, the instrument can be positioned higher or lower, indifferently (see Fig. 19 and 20). ). In this case, during set point calibration the **negative** or **positive** head must be taken into account.

### 7.2 SPECIAL NOTE FOR INSTALLATION OF CATEGORY 2 G D PRESSURE SWITCHES

The flameproof pressure switches **series BA** can be installed on processes and environments classified zone 1 or 21 (which require apparatus group II category 2G/D) **ONLY** if the process is **NOT FLAMMABLE**. (see Fig.7).

Fig. 7 - Installation of Group II Cat. 2 GD instruments  
Gas (G)                      Dust (D)

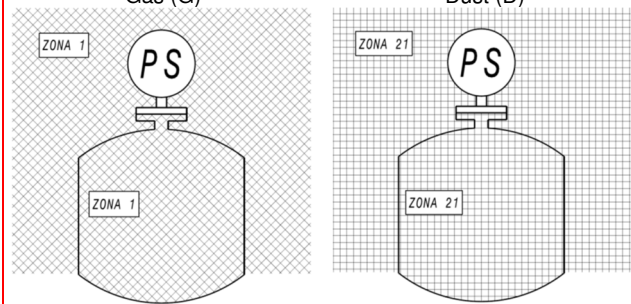

### 7.3 INSTRUMENT WITH DIAPHRAGM SEALS

When the pressure switch is mounted on diaphragm seal with capillary and the set point is less than 10 bar, the gap (distance h) between diaphragm seal and instrument generates a column of liquid, whose pressure equivalent constitutes a drift of set point. The set point has to be adjusted consequently.

Fig. 8 – Instrument with diaphragm seal

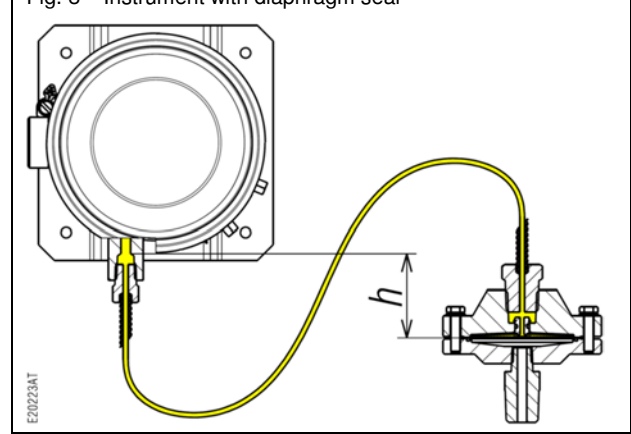

### 7.4 PRESSURE CONNECTIONS

For a correct installation it is necessary to:

**Mount** a shut-off valve with drain (root valve) on the process tube to allow the instrument to be excluded and the connection tubing to be drained. It is recommended that said valve has a capstan-blocking device aimed at preventing it being activated casually and without authorisation.

**Mount** a service valve near the instrument to permit possible functional verification on site. It is recommended that the service valve is closed with a plug to prevent the outlet of the process fluid caused by the incorrect use of said valve.

**Mount** a three-piece joint into the process connection to permit the easy mounting or removal of the instrument itself.

The pressure connection adaptor have to be installed as per Fig.9

Fig. 9 – Installation of pressure connection adaptor

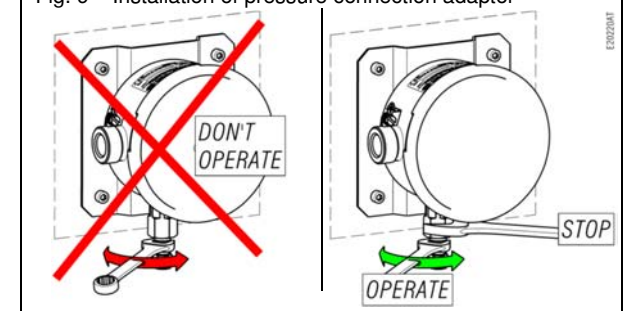

**Carry out** the connection to the process using a flexible tube in such a way that variations in the temperature of the tube itself do not force the instrument attachment.

**Ensure** that all the pressure connections are airtight. It is important that there are no leakages in the circuit.



Close the root valve and the relative drain device. Close the service valve using a safety plug.

### 7.5 INSTRUMENTS WITH DIAPHRAGM SEAL EQUIPPED WITH PROCESS CONNECTION COATED WITH PTFE

The pressure connection must be made in such a way that the part protruding from the instrument have to be used as a sealing ring.



### 7.6 ELECTRICAL CONNECTIONS

It is recommended to carry out the electrical connections according to the applicable standards.

In case of flameproof instruments and intrinsic safety instruments see also the Standard IEC/EN-60079-14. If the electrical connection is carried out in a protected tube, it shall be made so that condensate is prevented from entering instrument enclosure.

To guarantee the ingress protection IP66 and prevent loosening of the blocking joint or cable glands, it is prescribed to seal the threads with an anaerobic sealant. For example, use a sealant like Loctite ® 542.



**CAUTION:** fittings used for the electrical connection of the flameproof instruments shall be certified according the IEC or EN standards and shall guarantee instrument degree of protection (IP66). In the case of Gk threads, this is made in accordance with standard UNI-EN 60079-1 (Italian national variant).

The installation of the cable gland or three-piece joint should be as per fig. 11.

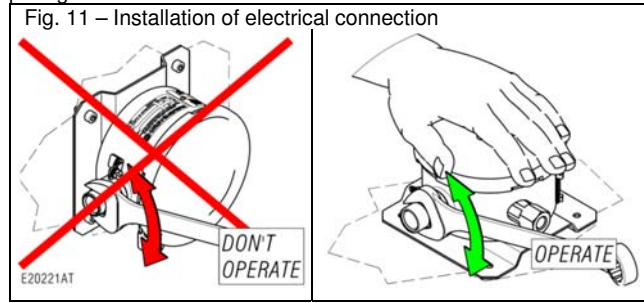

With the instrument into the final position provided that the electric line is not energize, remove the cover and make the electrical connection to the terminal block (see Fig. 2).



If the ambient temperature exceeds 60 °C is recommended to use cables suitable for operating temperatures of at least 105 °C.

Flexible cables with a maximum section of 1,5 mm<sup>2</sup> (16AWG) are recommended using the pre-insulated crimp ring terminal.

**Do not touch the adjustment screws and do not bend** the elastic microswitch supports in order to prevent the instrument calibration being altered.

Ensure that no deposits or wire ends remain inside the case.



**Warning:** The instrument may be equipped with one or two micro switches SPDT type. All the electrical connection must be part of intrinsically safe circuits. The relevant parameters for intrinsic safety are listed on the nameplate of the instrument.

The tightening of the cable gland or the three-piece joint must be performed as shown in Fig. 12

Fig. 12 – Installation of the cable gland

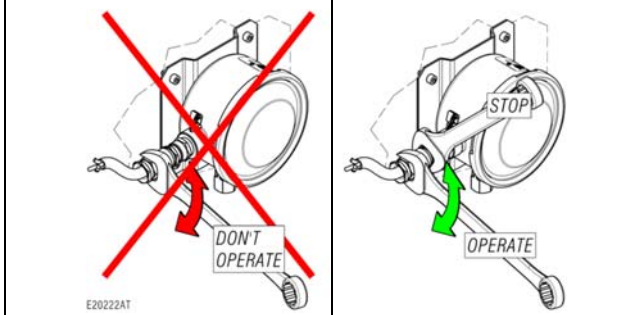

As soon as connection steps are completed, mount the cover on and make sure it is tight and blocked (See fig 4 and 5).

### 7.7 CONNETTOR 7 POLES TYPE MIL-5015 FOR WEATHER PROOF INSTRUMENT

The free connector, supplied with the instrument, is able to accept multicore cables with maximum outer diameter 11 mm. It is recommended flexible cables with single-conductor with a maximum section of 1.5 mm<sup>2</sup> (16AWG).

The cable have to be prepared as per fig. 13

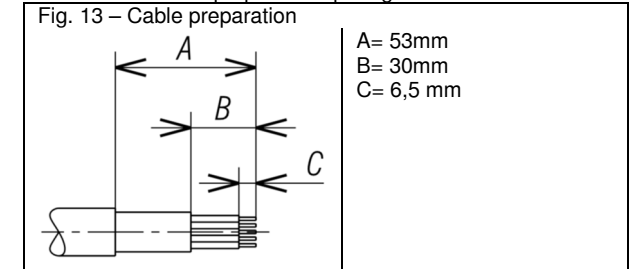

The single stripped conductor has to be crimped with each contact pin. For the electrical connections and for the assembly follow Fig.14.

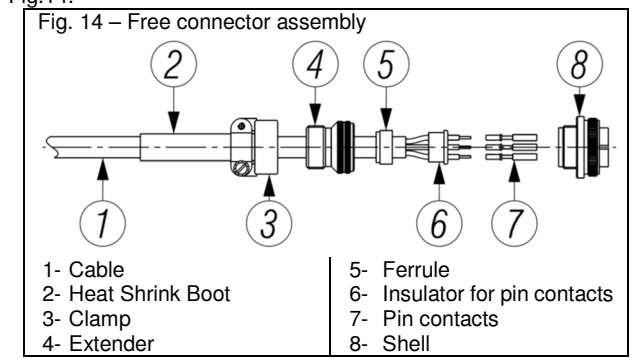

The wiring diagram is according Fig.15.

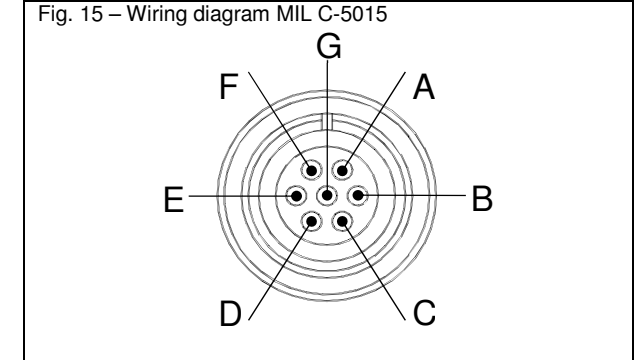

CONTACT	FUNCTION	
A	1-NA	Micro 1: Normaly open
B	1-NC	Micro 1: Normaly closed
C	1-C	Micro 1: Common
D	2-NA	Micro 2: Normaly open
E	2-NC	Micro 2: Normaly closed
F	2-C	Micro 2: Common
G	Ground	Internal grounding connection

Once the crimping and assembly activities of the free connector are finished, make sure that all the parts are tight. Screw the bayonet and tighten it to assure the instrument degree of protection

## 7.8 GROUNDING CONNECTIONS



The instrument is supplied with two grounding connections, one external and one internal. The connections are suitable for a earthing wires of 4 mm<sup>2</sup> section (fig. 2).

## 8 INSTRUMENT PLUMBING

### 8.1 Weatherproof pressure switches (Series BWX)

The plumbing, aimed as a guarantee against possible tampering of the calibration and electrical connections, can be carried out using a flexible steel wire (a) inserted into the holes in the screw (c) and the bracket (d) provided for this purpose (see Fig. 4).

### 8.2 Flameproof pressure switches (Series BA and BAX)

Plumbing is not necessary as the cover is blocked with a headless screw and the instrument **does not** have to be opened when installed (see Fig. 5).

## 9 SAFETY INTEGRITY LEVEL (SIL) INSTALLATION REQUIREMENTS

The pressure switches have been evaluated as Type A safety related hardware with a hardware fault tolerance of 0 used in one out one configuration (1oo1). Evaluate the installation necessity to permit a proof test to detect dangerous undetected fault as follows

- Take appropriate action to avoid a false trip
- Force the pressure switch to reach a define max or min threshold value and verify that output goes into the safe state.
- Force the pressure switch to reach a define normal threshold value and verify that output goes into the normal state.
- Repeat the check two times evaluating average set point value and repeatability,
- Restore the loop to full operation
- Restore normal operation

The installation requirements, the useful life and the failure of the pressure switch is discussed in the Failure Modes, Effects and Diagnostic Analysis Report

## 10 PUTTING INTO OPERATION

The instrument comes into operation as soon as is energized and the root valve is opened. Any possible drainage of the connection tubing can be carried out by removing the safety plug and **opening the service valve with the necessary caution.**



Do not dispose of the process fluid into the environment, if this can cause pollution or damage to people

## 11 VISUAL INSPECTION

Periodically check the external condition of the enclosure. There should be no trace of leakage of process fluid outside the instrument.

In case of flameproof or intrinsic safety instruments, inspections of the electrical installation are to be carried out also according to customer procedures and at least in accordance with Standard EN-60079-17.



The flameproof and the intrinsic safety instruments installed in explosive atmospheres for the combustible dust presence, must be periodically cleaned up externally in order to avoid dust accumulating.

### 11.1 INSTRUMENTS WITH DIAPHRAGM SEAL EQUIPPED WITH PROCESS CONNECTION COATED WITH PTFE

These instruments are usually installed on process with high corrosion resistance requirements. To verify the condition of PTFE the process connection is equipped with an inspection hole. During the visual inspection check the absence of fluid from the inspection hole. On the contrary the instrument have to be replaced.

## 12 FUNCTIONAL VERIFICATION

This will be carried out according to the Customer's control procedures. The instruments can be verified on the plant if installed as illustrated in Fig. 19 and 20.

To avoid any risk it is recommended check the set point on site without open the cover and without dismount the cable gland and without unplugging the power cable.

The flameproof or intrinsic safety instruments may be checked on site only if the apparatus used are suitable for explosive atmosphere.

If this is not the case it is necessary remove the instrument from the plant, and carry out the verification in a test room.

If the verification of the set point is performed unplugging the power cable from the terminal block it is recommended de-energize the instrument to avoid any electrical hazard.

### WARNING: Instrument series BA and BAX, flameproof.

Before open the cover or the cable gland check the absence of explosive atmosphere and check that the instrument is **not energized.**

Verification consists in **check the calibration value** and possibly regulating the adjustment bush (see §6).

### 12.1 INSTRUMENT WITH DIAPHRAGM SEAL

This instrument, because of their particular operating principle, if used as an alarm of max pressure, have to be functional inspected every year as minimum.

## 13 STOPPING AND DISMOUNTING

Before proceeding with these operations **ensure** that the plant or machines have been put into the **conditions** foreseen to allow these operations.

### With reference to Figures 19 e 20

Remove the power supply (signal) from the electrical line. Close the root valve (6) and open the drain. Remove the plug (2), open the valve (3) and wait until the process fluid has drained from the tubing through the drain.

Do not dispose of the process fluid into the environment, if this can cause pollution or damage to people.

Unscrew the three-piece joint (8).

### WARNING: Instrument series BA and BAX, flameproof.

Before open the cover or the cable gland check the absence of explosive atmosphere and check that the instrument is not energized.

Unscrew the three-piece joint (10) (electrical cable tubing).

Remove the instrument cover and disconnect the electrical cables from the terminal block and earth screws.

Remove the screws fixing the case to the panel (or pipe) and remove the instrument, taking care to slide the electrical conductors out from the case.

Mount instrument cover. Insulate and protect cables around, if any. Temporarily plug pipes not connected to the instrument.

In case of flameproof instruments or intrinsic safety it is recommended to follow - at least - the standard EN-60079-17 for the withdrawal from service of electrical apparatus.

## 14 DISPOSAL

The instruments are mainly made of stainless steel and aluminium and therefore, once the electrical parts have been dismantled and the parts coming into contact with fluids which could be harmful to people or the environment have been properly dealt with, they can be scrapped.





### 15 TROUBLESHOOTING

**IMPORTANT NOTE:** operations involving replacement of essential components must be carried out at our workshop, especially for instruments with flameproof certificate; this is to guarantee the user the total and correct restoration of the product original characteristics.



MALFUNCTION	PROBABLE CAUSE	REMEDY
<b>Set point shift</b>	<ul style="list-style-type: none"> <li>Wear of contacting surfaces between pin of microswitch and tip of sensing element.</li> <li>Wear of contacting surfaces between microswitch cradle and adjusting screw.</li> <li>Incrostation or corrosion of above mentioned surfaces.</li> <li>Permanent deformation of the sensitive element due to fatigue</li> <li>Variation of the elastic features of the sensitive element due to its chemical corrosion.</li> </ul>	<ul style="list-style-type: none"> <li>Recalibrate</li> <li>Recalibrate</li> <li>Clean surfaces and recalibrate. Check the enclosure tightness</li> <li>Recalibrate</li> <li>Recalibrate or replace the sensitive element with another made of a suitable material. If necessary apply a fluid separator.</li> </ul>
<b>Low repeatability</b>	<ul style="list-style-type: none"> <li>Assembling screws loosened.</li> </ul>	<ul style="list-style-type: none"> <li>Check fixing screws of electrical assembly and regulation assembly.</li> </ul>
<b>Slow response</b>	<ul style="list-style-type: none"> <li>Clogged or obstructed connection line.</li> <li>Root valve partially closed.</li> <li>Too viscous fluid.</li> </ul>	<ul style="list-style-type: none"> <li>Check and clean line.</li> <li>Open valve.</li> <li>Provide instrument with suitable fluid separator.</li> </ul>
<b>No actuation or undue actuation</b>	<ul style="list-style-type: none"> <li>Microswitch contacts damaged.</li> <li>Loosened electrical joints.</li> <li>Interrupted or short-circuited electrical line.</li> </ul>	<ul style="list-style-type: none"> <li>Replace the Microswitch.</li> <li>Check all electrical joints.</li> <li>Check the conditions of the electrical line.</li> </ul>
<b>Undue actuation</b>	<ul style="list-style-type: none"> <li>Accidental shocks or excessive mechanical vibrations.</li> </ul>	<ul style="list-style-type: none"> <li>Modify the mounting.</li> </ul>

Fig. 16 – BW Mounting of brackets for 2" pipe

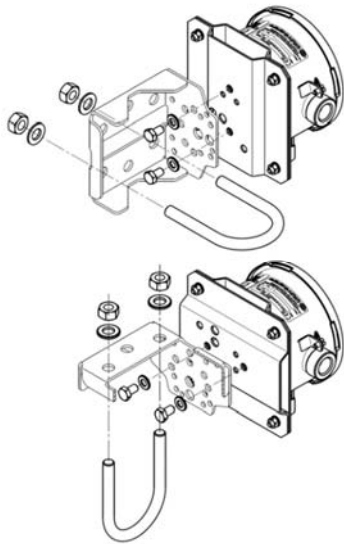
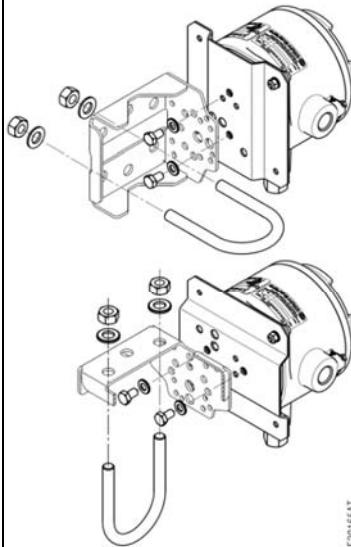

Fig. 17 – BA and BAX Mounting of brackets for 2" pipe



E2016SAT

- 13- M6 screws
- 14- Bracket for 2" pipe
- 15- Vertical pipe
- 16- Horizontal pipe

Fig. 18 – Example of mounting Series BW and BA

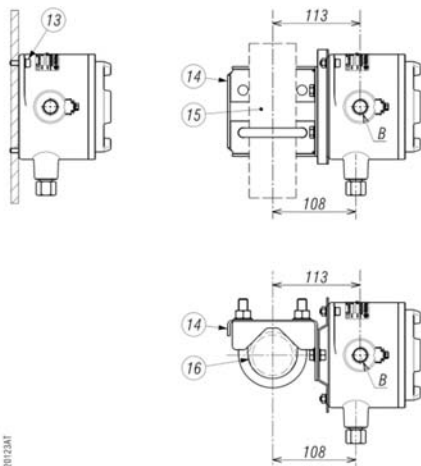

E2012SAT

Series BAX

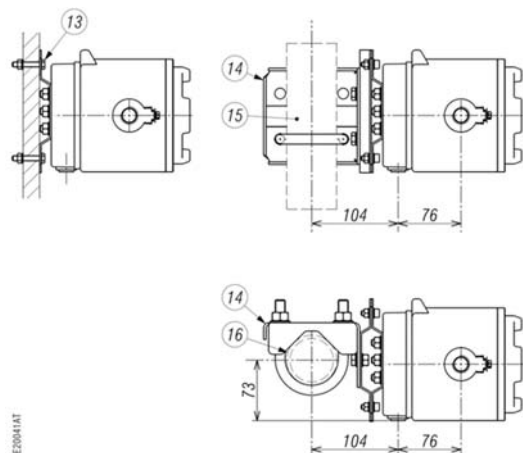

E2004IAT

Fig. 19 Example of connections -

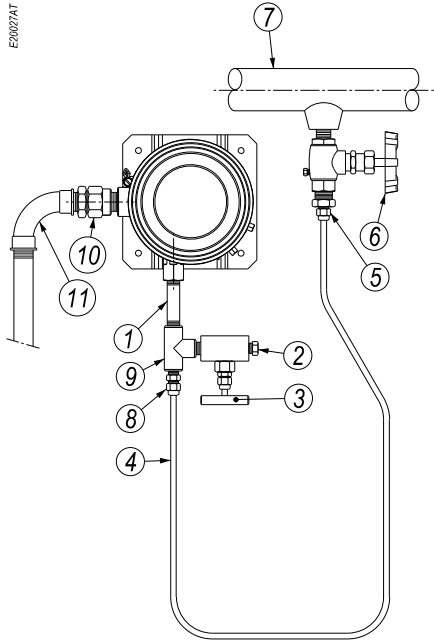
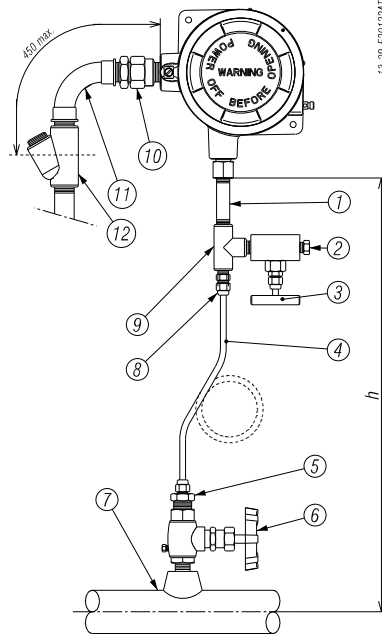

Fig. 20 Example of connections -



**LEGENDA**

- 1 - Fitting
- 2 - Drain plug
- 3 - Service valve
- 4 - Piping
- 5 - Three piece fitting
- 6 - Root valve with drain

- 7 - Process piping
- 8 - Three piece fitting
- 9 - "T" fitting
- 10 - Three piece fitting
- 11 - Curve
- 12 - Blocking joint

**NOTE** With gas or vapour process fluid, the instrument **must** be positioned higher than the pipe inlet (see Fig. 20). With a liquid process fluid, the instrument can be positioned higher or lower, indifferently (see Fig. 19 e 20). In this case, during set point calibration the **negative** or **positive head** must be taken into account (distance h in Fig.19 and 20).

Fig. 21 – Montaggio in armadio

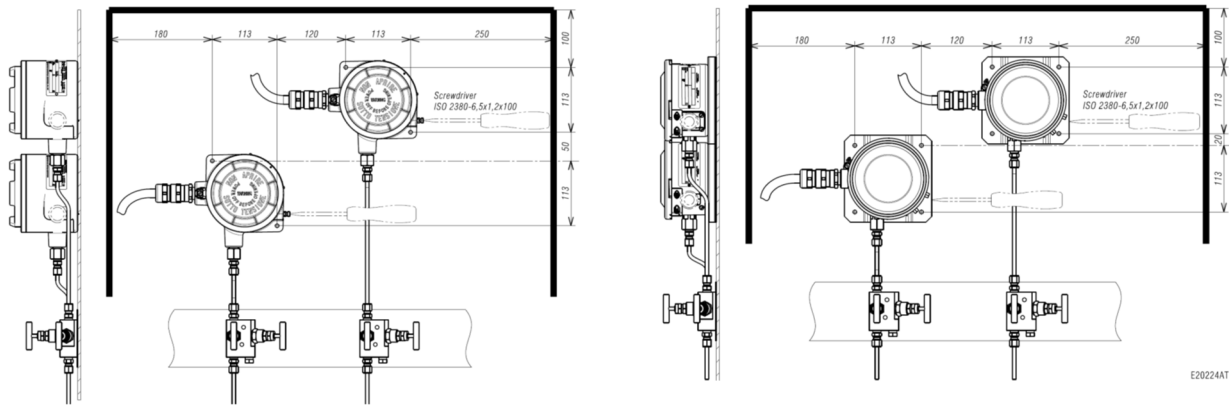

**Annex 1 – Model Code**

